

FRONT VIEW

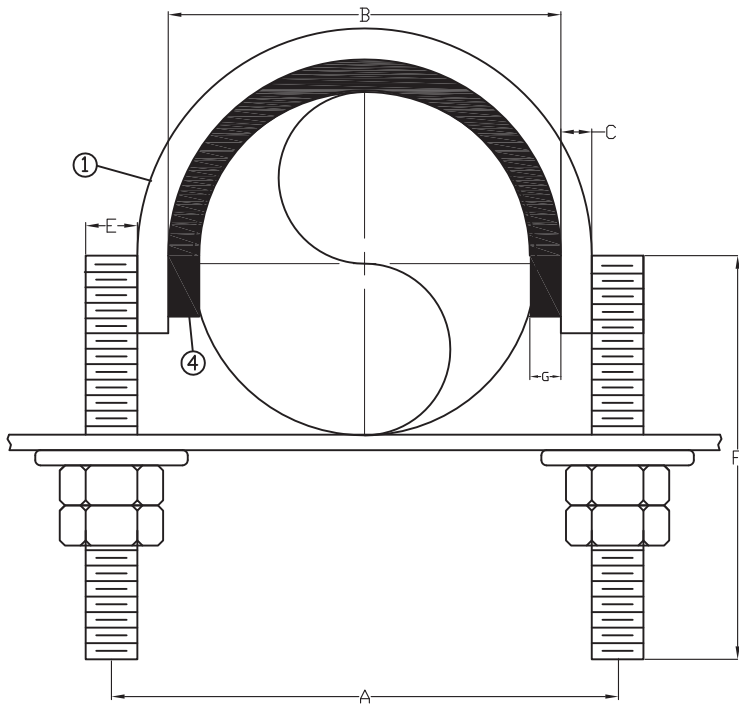

SIDE VIEW

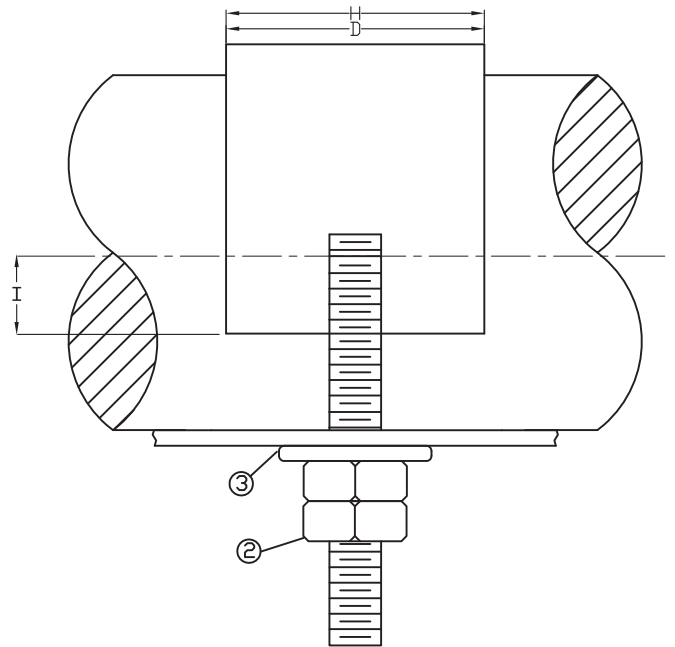

Urethane-lined Hold Down Strap Dimensions

| Pipe Size (in.) NPS | Metallic Strap Dimensions (in.) | | | | | | Liner Dimensions (in.) | | Center of pipe to BOS* (in.) |
|---------------------------|---------------------------------|--------|-----|---------|-----|---------|---------------------------|---------|---------------------------------|
| | A | B | C | D | E | F | G | H | |
| 1 | 2 11/16 | 2 | 1/4 | 1 15/16 | 3/8 | 2 3/4 | 1/4 | 1 15/16 | 1-1/2 |
| 1.5 | 3 3/8 | 2 9/16 | 1/4 | 1 15/16 | 3/8 | 2 15/16 | 1/4 | 1 15/16 | |
| 2 | 3 7/8 | 3 | 1/4 | 1 15/16 | 3/8 | 3 | 1/4 | 1 15/16 | |
| 3 | 5 1/8 | 4 1/8 | 1/4 | 1 15/16 | 1/2 | 4 | 1/4 | 1 15/16 | |
| 4 | 6 1/8 | 5 1/8 | 1/4 | 1 15/16 | 1/2 | 4 1/2 | 1/4 | 1 15/16 | |
| 6 | 8 7/8 | 7 1/4 | 1/4 | 1 15/16 | 5/8 | 5 3/4 | 1/4 | 1 15/16 | |
| 8 | 10 3/8 | 9 1/4 | 1/4 | 1 15/16 | 5/8 | 7 | 1/4 | 1 15/16 | 2 |
| 10 | 12 7/8 | 11 3/8 | 3/8 | 2 9/16 | 3/4 | 8 | 1/4 | 2 9/16 | |
| 12 | 15 | 13 3/8 | 3/8 | 2 9/16 | 7/8 | 9 3/8 | 1/4 | 2 9/16 | |
| 14 | 16 1/4 | 14 5/8 | 3/8 | 2 9/16 | 7/8 | 10 5/8 | 1/4 | 2 9/16 | 3 |
| 16 | 18 1/2 | 16 5/8 | 1/2 | 2 15/16 | 7/8 | 11 1/2 | 1/4 | 2 15/16 | |
| 18 | 20 5/8 | 18 5/8 | 1/2 | 2 15/16 | 1 | 13 | 1/4 | 2 15/16 | |
| 20 | 22 5/8 | 20 5/8 | 1/2 | 2 15/16 | 1 | 14 | 1/4 | 2 15/16 | |
| 24 | 26 5/8 | 24 5/8 | 1/2 | 2 15/16 | 1 | 16 | 1/4 | 2 15/16 | |

* BOS = Bottom of Strap

NOTES:

1. Hold down strap to be hot-dipped galvanized (other finishes available upon request).
2. Liner to be APP-UT80A Urethane (Urethane properties can be modified if necessary for hardness parameters).
3. Custom dimensions available upon request.
4. Temperature Range: -40°F to +175°F.

| ITEM | QTY | DESCRIPTION | Material |
|------|-----|-----------------|--------------------|
| 1 | 1 | Hold Down Strap | HDG CS |
| 2 | 4 | Nuts | HDG CS |
| 3 | 2 | Washers | HDG CS |
| 4 | 1 | Liner | APP-UT80A Urethane |

| | | | | | | |
|-------------------------------------------------------------------------------------------------------|-------|------|-------------------------------------------------------------------------------------------------------------------------------|-----------|--------------|--|
| CUSTOMER DATE: CD. NAME: CONTACT: N° PROGEN: N° CLIENT: CLIENT: PROJECT: REF: | DWN. | DATE | 05-29-2015 | | | |
| | CHK. | | | | | |
| | ENG. | | | | | |
| | APPR. | | | | | |
| | MFG. | APP | S.D. | | | |
| | | | | | | |
| | | | | | | |
| | | | | | | |
| | | | ADVANCED PIPING PRODUCTS 5611 Guhn Road Suite A1, Houston, TX 77040 Tel. 713-956-2922 Fax 713-956-4090 www.appinc.co | | | |
| | | | DWG DESCRIPTION Urethane-lined Hold Down Strap | | | |
| | | SIZE | A | ULHDS0515 | REV. 0 | |
| NEXT ASSY | | QTY | SCALE | NONE | EST. WT. | |
| | | | | | SHEET 1 OF 1 | |